

## FITTING INSTRUCTIONS

### ADJUSTABLE CANOPY STAYS WITH FRICTION IPA NO.s 62586-87 + 89

EXAMPLE WOOD PROFILE:

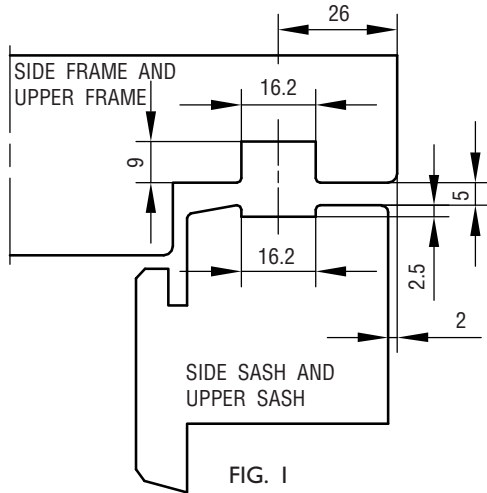

FIG. 1

HORIZONTAL PLANE

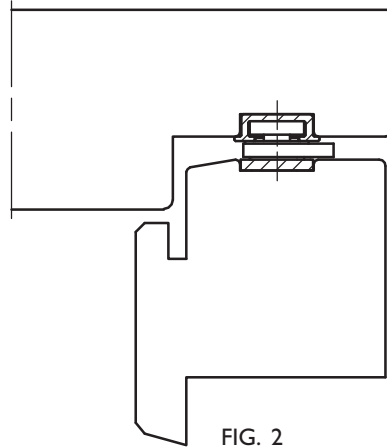

FIG. 2

**OBS! RE. IPA NO. 62587:**

FOR BIG WINDOWS (>1200 MM) WITH 3-LAYER GLASS AND NO REQUIREMENTS FOR EGRESS OPENINGS THE USE OF IPA NO. 62589 IS RECOMMENDED, AS THE VENTILATION POSITION OTHERWISE MAY BE DIFFICULT TO ACHIEVE BECAUSE OF THE OPENING GEOMETRY OF THE GEARS.

IPA NO.	62586	62587	62589
MAX. SASH WEIGHT KG	40	50	70
MAX. INSIDE FRAME HEIGHT MM	844	1344	1544
USE SCREW NO.	4.0	4.0	4.0

**ESPECIALLY FOR IPA NO. 62587 OG 62589:**

THE SCREW IN THE TOP OF THE FRICTION ELEMENT IS ONLY TO ENSURE THAT THE GLIDING ELEMENT BELOW MOVES CORRECTLY IN THE ALUMINIUM RAIL. THEREFORE THIS SCREW MUST NOT BE ADJUSTED.

#### FITTING:

- CLOSE THE FITTING AND PLACE IT IN THE GROOVE OF THE SIDE FRAME. PLACE THE FITTING AGAINST THE TOP FRAME. PLACE AND FASTEN THE SCREW IN THE BOTTOM HOLE OF THE FITTING.
  - 62587: FASTEN THE STOP PLATE THROUGH THE UPPER SCREW HOLE IN THE STOP PLATE AND THROUGH THE UPPER SCREW HOLE IN THE ALURAIL. THIS ENABLES MAX. FIRE ESCAPE OPENING. USE LOWER SCREW HOLE IN STOP PLATE TO ACHIEVE A MAX. SASH LOAD OF 60 KGS. IF LOWER SCREW HOLE IS USED THE FIRE ESCAPE OPENING WILL BE REDUCED.
  - 62589: ALWAYS USE THE UPPER SCREW HOLE IN THE ALURAIL FOR FASTENING THE STOP PLATE. USE THE UPPER SCREW HOLE IN STOP PLATE FOR MAX. FIRE ESCAPE OPENING. USE THE MIDDLE SCREW HOLE IN THE STOP PLATE TO ACHIEVE A MAX. SASH LOAD OF 85 KGS. USE THE LOWER SCREW HOLE IN THE STOP PLATE TO ACHIEVE A MAX. SASH LOAD OF 100 KGS. IF MIDDLE OR LOWER SCREW HOLES IN STOP PLATE ARE USED THE FIRE ESCAPE OPENING WILL BE REDUCED.
- PUSH THE SASH INTO ITS PLACE BY INSERTING IT BETWEEN THE HINGE ARMS, GUIDED BY THE GROOVES IN THE SASH, UNTILL THE SASH HITS THE STOPS OF THE FITTING. THESE STOPS WILL GUARANTEE A 5 MM GAB BETWEEN FRAME AND SASH. FASTEN THE FITTING STARTING WITH THE SCREW IN THE STOP BRACKET.
- NOW THE FRICTION MAY BE ADJUSTED BY MEANS OF THE SCREWS IN THE SLIDES. THE BEST RESULT FOR THE WINDOW MOVEMENT IS ACHIEVED BY EQUAL FRICTION AT EITHER SIDE.
- THE SASH CAN BE ADJUSTED  $\pm 1.5$  MM UP OR DOWN. ADJUST BY USING A TORX-20 KEY TO TURN THE ECCENTRIC SCREW. BY DELIVERY THE MARK ON TH ECCENTRIC SCREW IS IN A VERTICAL POSITION INDICATING THE 0-POSITION. WHEN THE MARK IS IN HORIZONTAL POSITION IN EITHER TOP OR BOTTOM, THE FITTING IS ADJUSTED TO IT'S MAX OF  $\pm 1.5$  MM.

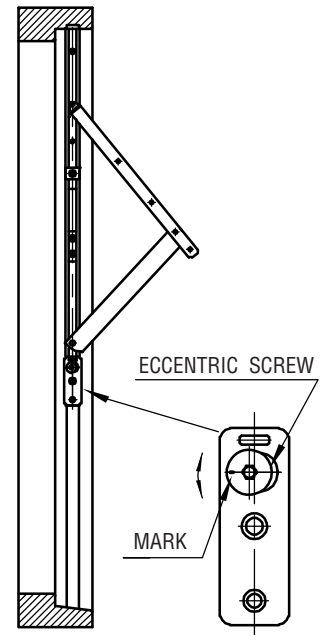

FIG. 3

#### MAINTENANCE:

THE FITTINGS ARE NOT TO BE PAINTED. TEST THE OPERATION FROM TIME TO TIME. WHEN FITTING - LUBRICATE THE PIVOT/MOVABLE METAL PARTS OF THE MECHANISM WHILE ACTIVATING REPEATEDLY. HEREAFTER LUBRICATE MINIMUM TWICE A YEAR. DO NOT LUBRICATE THE ALUMINIUM RAILS.